

COMPUTER SIMULATION HISTORY

519.6

DOI 10.18413/2411-3808-2019-46-4-689-699

APPLICATION OF THE METHOD BELLMAN DYNAMIC PROGRAMMING FOR THE IMPLEMENTATION OF HIGH-RELIABLE PROCESSING SYSTEMS ELECTRONIC MEDICAL DATA

1, 2, 3
M.V. Korolev¹, L.Yu. Koroleva², A.I. Motienko³

- « , 302034, .35
- 2) « , 302026, .95
- 3) - , 199178, , 14 . .39,

Federal state military educational institution of higher professional education "Academy of the Federal security service of the Russian Federation", 35 Priborostroitelnaya St, Orel, 302034, Russia

²⁾ Federal State Budgetary Educational Institution of Higher Education "Orel State University. I.S. Turgenev ", 95 Komsomolskaya St, Orel, 302026, Russia

³⁾ St. Petersburg Institute for Informatics and Automation of the Russian Academy of Sciences, 39, 14-th Line V.O., St. Petersburg, 199178, Russia

E-mail: korol80@list.ru, mivi2009@rambler.ru, anna.gunchenko@gmail.com

() ,

,

()

- , .

(,),

,

- ,

-

« »

()

Abstract

The aim of the work is to analyze the possibilities of applying the Bellman dynamic programming method to create highly reliable (fault-tolerant) systems designed for processing electronic medical data for various purposes. It is shown in the work that the fulfillment of the specified requirements for the reliability of such systems can be ensured by ensuring the redundancy (organization of redundancy) of the system components - both hardware and software. The authors substantiated specific scientific and technical proposals for optimizing and calculating the number of redundant system components (in particular, for the required multiplicity of backup databases that underlie electronic medical data processing systems), allowing to fulfill the established requirements for the reliability of such systems while reducing costs their implementation, as well as relevant examples of calculations. The mathematical apparatus of probability theory and reliability theory, as well as linear programming, in particular, the Bellman dynamic programming method, is used in this work. In addition, the paper presents scientific and technical proposals for the use of the concept of “absolutely reliable” systems that are widely used in reliability theory in organizing highly reliable electronic medical data processing systems. Systems implemented using this approach will ensure that the specified requirements for their reliability are met, while simpler (qualitative) reliability criteria can be used to evaluate them in practice.

: , « »

Keywords: electronic medical data processing systems, databases, redundancy of hardware and software components of the system, “absolutely reliable” systems, Bellman dynamic programming.

()

[, 2016; , 2017; , 2018].

() ,)

())

())

())

())

())

() ,)

())

() ,)

[, 2012;

2019].

())

(,) .)

())

())

(),

(), ()

()

()

(,).

(), ().

(,), ()

(), ()

(), ()

(,)

() (),

(, $\alpha < 0,025$),

() 1.

t_{1-2} , ().

()

(), 2.

1
Table 1

()
The probability of component failure (databases of various types) and their cost

()	, q_i	C_i , . . .
1	0,2	5
2	0,1	4
3	0,15	3

2
Table 2

()
Solution options in the first step (for two databases)

	2=0	2=1	2=2
	0,1/4	0,01/8	0,001/12
1=0; 0,2/5	0,3/9	0,21/13	0,201/17
1=1; 0,04/10	0,14/14	0,05/18	0,041/22
1=2; 0,08/15	0,108/19	0,018/23*	0,009/27*

2 :
-
, ^1,2;

(), 1,2.
q1,2 1,2 :

$$q_{1,2}^{r+1} = q_1^{r+1} + q_2^{r+1} - q_1^r \cdot q_2^r \cdot q_1 + q_2^r \cdot q_1^r \cdot q_2$$

$$C_{1,2} = C_1(q_1^{r+1}) + C_2(q_2^{r+1})$$

A_1, A_2 - ()

2 ,
(), «*».

()

3

3, :

$$q_{1,2,3}^{r+1} = q_{1,2}^{r+1} + q_3^{r+1} - q_3^r \cdot q_{1,2}^r \cdot q_3$$

$$^{\wedge}1,2,3 = ^{\wedge}1,2 + C_3(q_3^{r+1}) - (1)$$

$$r_i=2, \quad 2=1, \quad 3=2,$$

3
Table 3

()
Solution options in the second step (for three databases)

	2	
	1=2 2=1	1=2 2=2
3=0; 0,15/3	0,018/23	0,009/27
3=1; 0,023/6	0,168/26	0,159/30
3=2; 0,003/9	0,041/29	0,032/33
	0,021/32	0,012/36*

$$q = 0,021.$$

(, ri=0)

()
()
« »

[, 2003]

(), « »

().
()

[, 2003].

1. () « » ()
2. () ; « » m ()

() « » ()
),
 ()
).

1. ()

$$= 2 \cdot 10^{-7}$$

(
 0,999; 0,99 0,9).
 « ».

$$P(t) = e^{-\int_0^t A(t) dt} \quad A(t) = \text{const}$$

$$nAt < -\ln p$$

$$(\hat{N}) = e^{-nAt}$$

$$t_p = \frac{-\ln 0,999}{2,10 \cdot 10^{-7} - 50} = 100$$

$$0,99,$$

Henp $\frac{2 \cdot 10^{-7} - 50}{2,10 \cdot 10^{-7} - 50} = 1000$;

$$t_p = \frac{1 - 0,999}{2,10 \cdot 10^{-7} - 50} = 1050$$

() « »

2. « »

), (

$$(\hat{N}) = q(t_H e^{-p})^m$$

(1) - ()
 , m-

$$m = \frac{\ln(\hat{N})}{\ln q(t_H e^{-p})} - 1$$

:

m
()
()
4.
4
Table 4

« »
The number of backup elements of an absolutely reliable system

		m
0,999		3,292 « 4
		2
		2,641 « 3
0,99		1,861 « 2
		1
		1,427 « 2
0,9		0,431 « 1
		1
		0,214 « 1

., 2018; . 1 [. 2008; . 2012; ., 2019].

()

()

() -

« »

« ».

« » [., 2003].

« »:

() [., 2003]:

$$\sum_{i=1}^n Z_i = Z - ZP(44) P(4A,A) - \dots + (-1)^{n-1} (, .)$$

i, j, k

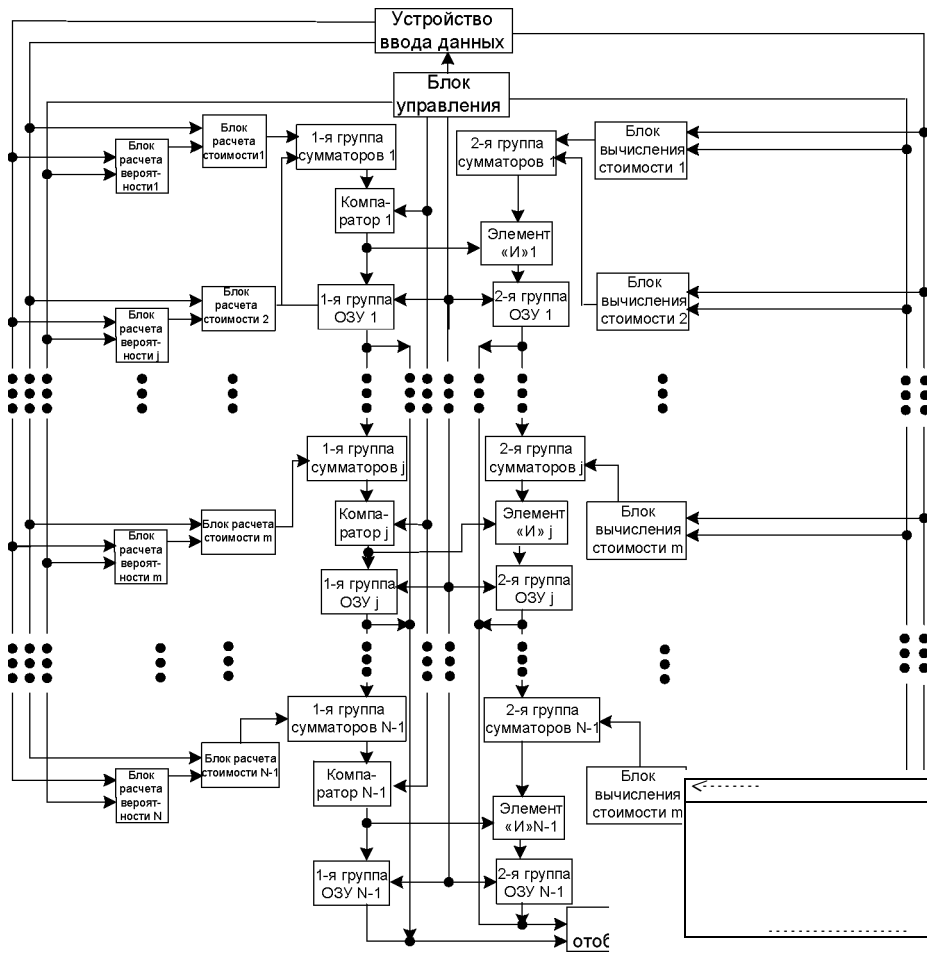

. 1.
Fig. 1. Device for solving optimization problems

« ... », [... , 2003; ... 2012; ... , 2019]: ... (...); ... (...) ... « ... », ... (... , ...) [... , 2018; ... , 2019],

(18-07-00380, 19-07-00832), (0073-2019-0004, 08-08).

The study was carried out with the financial support of the Russian Foundation for Basic (projectu 18-07-00380, 19-07-00832, by the state research 0073-2019-0004, partial financial support of the Government of the Russian Federation (grant 08-08).

1. 2018.
2. . . . 2018. . 45(3): 584-594.
3. . . . 2017. . 10: 6-17.
4. . . . 2008. . 3: 6-22.
5. 2320006. . . . 2012.
6. : . . . 4(294): 111-120. . . . 2019.
7. 2018. . 1 (56). 183386.
8. 2018.
9. 2003. . : - . 704 .
10. 2016. . 6.
11. 2019. . 46(2): 283-295.
12. Boudec J. 1998. Application of Network Calculus To Guaranteed Service Networks. IEEE Trans. on Information Theory, 44 (3). Available at: <https://infoscience.epfl.ch/record/27/files/LeBoudec98.pdf> (accessed 17 2019).
13. Grant A.E. 2016. Communication Technology Update and Fundamentals. Routledge N.Y. 704 p.
14. Goleniewski L., Wilson K. 2006. Telecommunications Essentials, Second Edition: Amazon Digital Services LLC. 928 p.

References

1. Basov O.O., Mironov O.Yu., Silkoviy D.V. 2018. Modeling real-time data streams in secure corporate communication networks based on deterministic calculus. Nauchnye vedomosti Belgorodskogo gosudarstvennogo universiteta - Scientific reports of Belgorod State University. 45 (3): 584-594. (in Russian)
2. Gurov A.N., Ogneva E.Ju., Plutnitsky A.N., Davronov I.V. 2018. Application of a software package for analyzing the effectiveness of a new work management of outpatient hospitals and identifying causes of patients' dissatisfaction with primary health care. Vrach i informacionnye tehnologii - Information technologies for the Physician. 10: 6-17. (in Russian).
3. Karpov O.E., Subbotin S.A., Shishkanov D.V., Zamyatin M.N. 2017. Digital public health. Necessity and background. Vrach i informacionnye tehnologii - Information technologies for the Physician. 3: 6-22. (in Russian).

4. Korolev M.V. et al. 2008. Ustrojstvo dlja reshenija zadach optimizacii [A device for solving optimization problems]. Patent RF for the invention 2320006. (in Russian).
5. Korolev M.V., Larkin E.I., Ivanov Yu.B. 2012. Securing voice information when using SVAZ. *Fundamental'nye i prikladnye problemy tehniki i tehnologii: Gosuniversitet-UNPK - Fundamental and applied problems of engineering and technology: State University-UNPK.* 4(294): 111-120. (in Russian).
6. Korolev M.V., Savin L.O. 2019. Optimization of control and maintenance parameters of critical AT units during its operation in special conditions. *Vestnik MADI - Vestnik MADI.* 1 (56). (in Russian).
7. Korolev M.V., Savin L.O., Officers A.I. 2018. Ustrojstvo dlja obespechenija opredelenija kolichestva rezervnyh jelementov sistemy [A device for determining the number of redundant system elements]. Patent RF for utility model 183386. Bull. 26.
8. Kuchukova N.N., Vershkov N.A. 2018. The mathematical model of the subsystem for searching and ranking documents in information retrieval systems. *Nauchnye vedomosti Belgorodskogo gosudarstvennogo universiteta - Scientific Bulletin of the Belgorod State University.* 45(1): 584-594. (in Russian)
9. Polovko A.M., Gurov S.V. 2003. *Osnovy teorii nadezhnosti [Fundamentals of reliability theory].* St. Petersburg: BHV-Petersburg. 704 p.
10. Rodikov M.V., Kochetova L.V., Pakhomova R.A. 2016. Models of doctor-patient interaction in modern medicine. *Sovremennye problemy nauki i obrazovanija - Modern problems of science and education.* 6. (in Russian).
11. Serebrovsky V.V. 2019. Study of the effectiveness of combining the search and compression of symbolic information. *Nauchnye vedomosti Belgorodskogo gosudarstvennogo universiteta - Scientific reports of Belgorod State University.* 46(2): 283-295. (in Russian)
12. Boudec J. 1998. Application of Network Calculus To Guaranteed Service Networks. *IEEE Trans. on Information Theory,* 44 (3). Available at: <https://infoscience.epfl.ch/record/27/files/LeBoudec98.pdf> (accessed: 17 September 2019).
13. Grant A.E. 2016. *Communication Technology Update and Fundamentals.* Routledge N.Y. 704 p.
14. Goleniewski L., Wilson K. 2006. *Telecommunications Essentials, Second Edition: Amazon Digital Services LLC.* 928 p.

For citation

. . . 2019.

. 46 (4): 689-699. DOI 10.18413/2411-3808-2019-46-4-689-699

Korolev M.V., Koroleva L.Yu., Motienko A.I. 2019. Application of the method Bellman dynamic programming for the implementation of high-reliable processing systems electronic medical data. *Belgorod State University Scientific Bulletin. Economics. Information technologies.* 46 (4): 689-699 (in Russian). DOI 10.18413/2411-3808-2019-46-4-689-699